

Flavor Burst®

SYR 944A FB 80a Syrup Tube & Bag Connector Assembly (18.5") Installation

The Syrup Tube & Bag Connector Assembly is for use with the Flavor Burst® soft serve systems. The newly designed Syrup Tube Assembly replaces the existing tube assembly to allow a simpler, cleaner, and more secure connection to the syrup bag. In order to properly install the new Syrup Tube Assembly, a Syrup Bag Adapter must be installed on the syrup bag. Refer to your Operations Manual for instructions on performing the Clean-In-Place, Pump Flush and priming procedures. Contact your local distributor for more information.

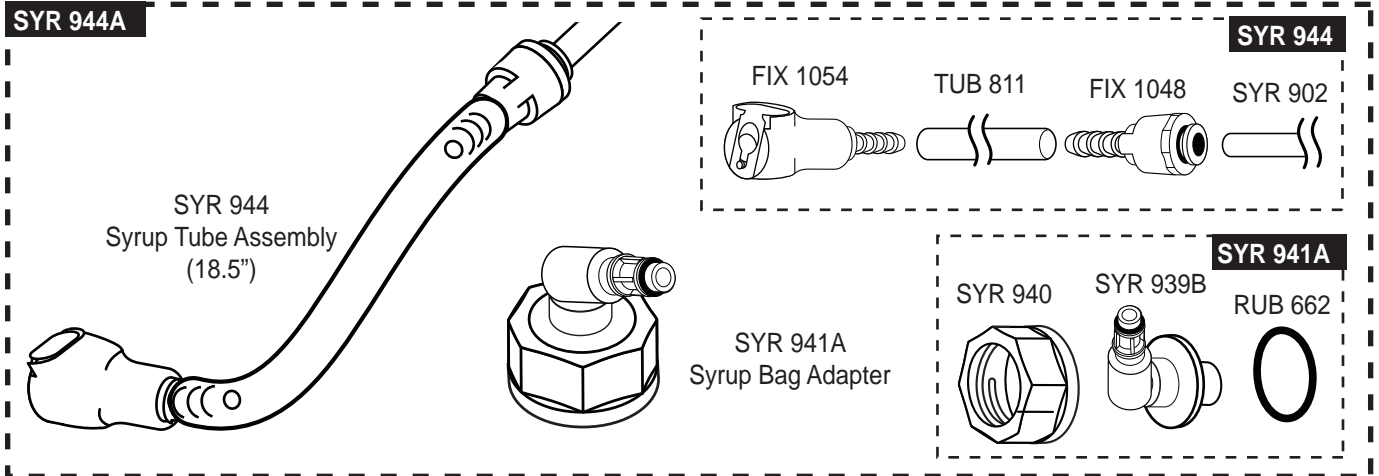

- 1 Perform Phase 2: Syrup System Cleaning of the CLEAN-IN-PLACE (CIP) PROCEDURE for the syrup tube that is being replaced. Refer to the Flavor Burst® Operations Manual for instructions.



NOTE: DO NOT RECONNECT THE SYRUP BAG CONNECTORS TO THE BAG FITMENTS.

- 2 Remove the back panel of the cabinet. Disconnect the syrup tube from the elbow fitting of the syrup pump.

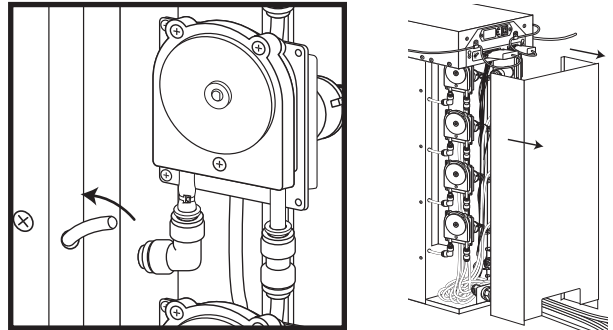

- 3 Remove the Syrup Tube Assembly from the cabinet.

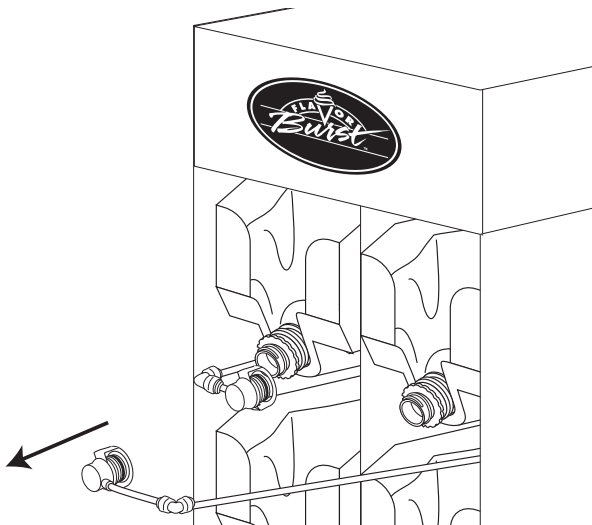

- 4 Slide the new SYR 944 Syrup Tube Assembly through the support railing to the back of the cabinet.

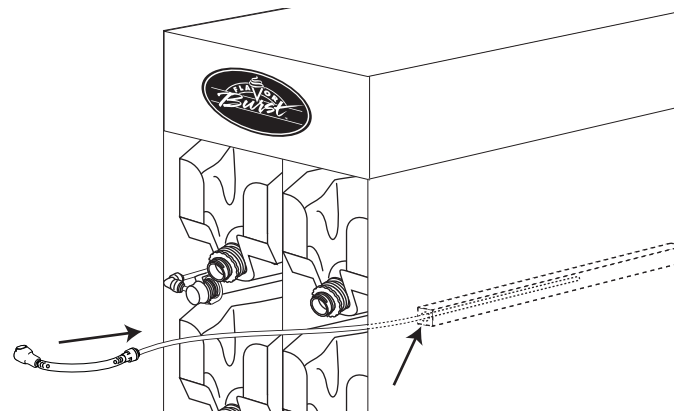

- 5** Insert the syrup tube fully into the elbow fitment of the syrup pump. Reinstall the back panel and the screw.

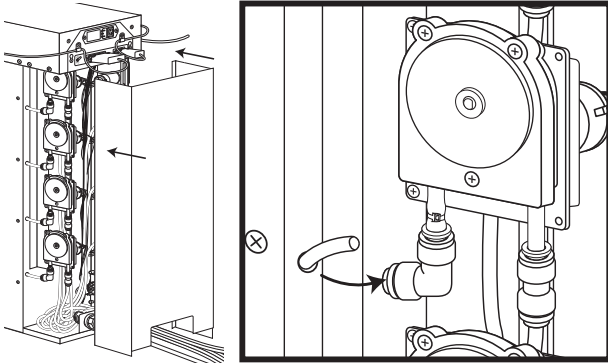

- 6** Spray the Syrup Bag Connector with sanitizer solution and allow it to sanitize for at least one minute.

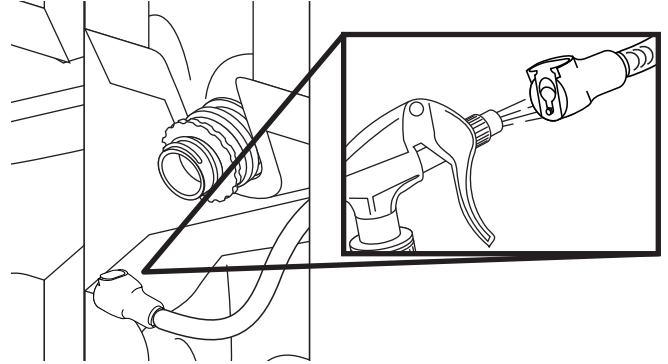

- 7** Install the Syrup Bag Adapter onto the bag fitment.

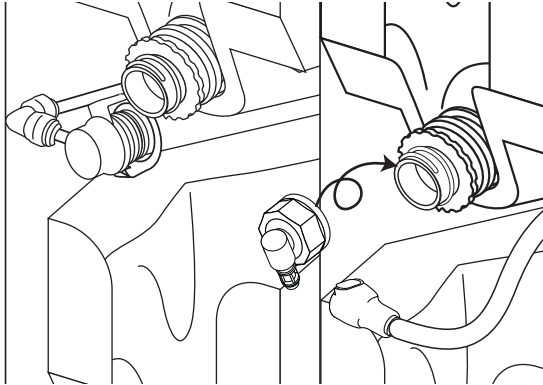

- 8** Hold the base of the adapter and turn the adapter valve toward the syrup line.

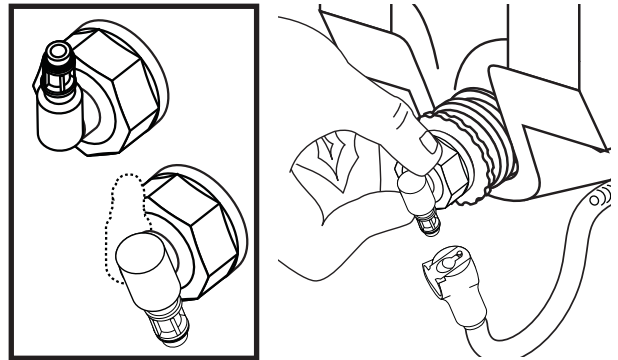

- 9** Connect the Syrup Bag Connector to the Syrup Bag Adapter.

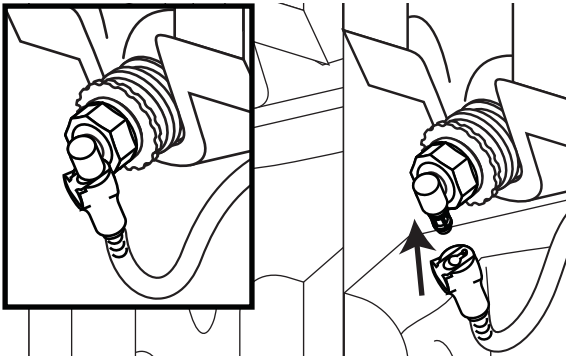

- 10** With a container under the Injector Head, press the numbered key corresponding to the syrup line (1-8) and then press the PUMP FLUSH key.

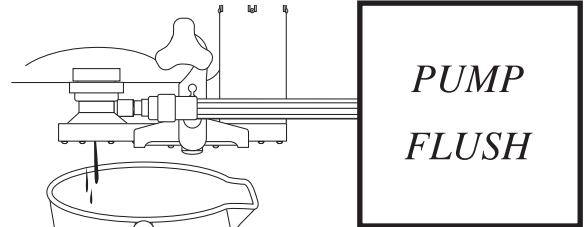

NOTE: FOR NEWER SYSTEMS, PRESS THE NUMBERED KEY CORRESPONDING TO THE SYRUP LINE AND THEN PRESS THE FLUSH KEY.

- 11** Press the FLUSH key to clean the Injector Head.

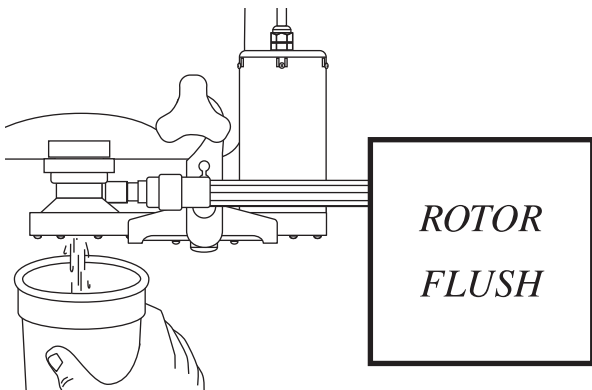

- 12** When cleaning the syrup line, remove the Syrup Bag Adapter from the bag fitment and install it on the Pump Flush Adapter. Then connect it to the Syrup Bag Connector and perform the Pump Flush procedure.

