

Flavor Burst™

MIS 3026 Surface Raceway Casing Installation

The Surface Raceway Casing is designed to hold and support Flavor Burst system cables and/or syrup tube lines. The Casing should be installed on the freezer in such a way that the cables or tubes do not interfere with daily operations. Do not install the Raceway over any seams or air vents on the freezer that may impede servicing the freezer or prevent venting the freezer.

MIS 3026

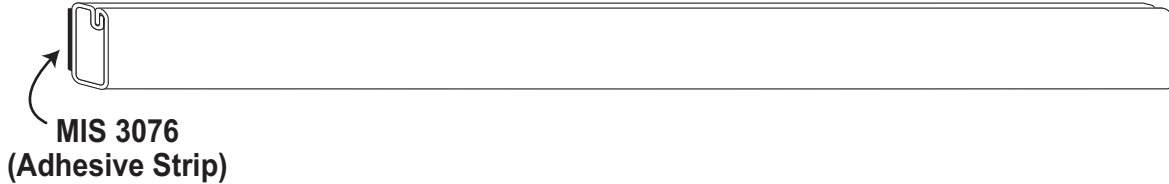

- 1** Thoroughly clean, rinse and dry the area where the Surface Raceway Casing will be mounted using detergent water, clean water, and single service towels.

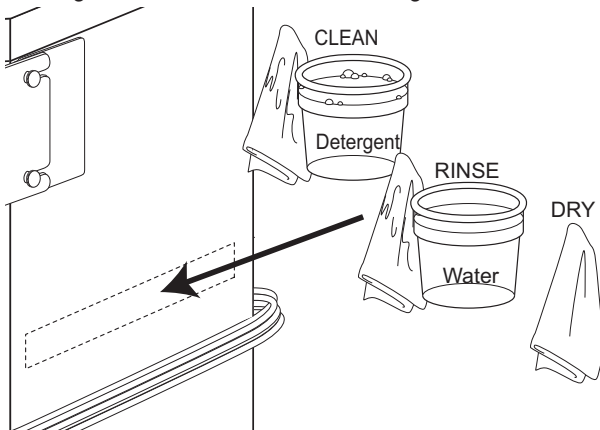

NOTE: FOR SYSTEMS WITH 9-TUBE ASSEMBLIES, ENSURE THE CASING IS MOUNTED AT THE SAME HEIGHT AS THE BLENDING / INJECTOR ASSEMBLY.

- 2** Remove the protective adhesive tape from the Casing and press the Casing onto the desired area on the freezer.

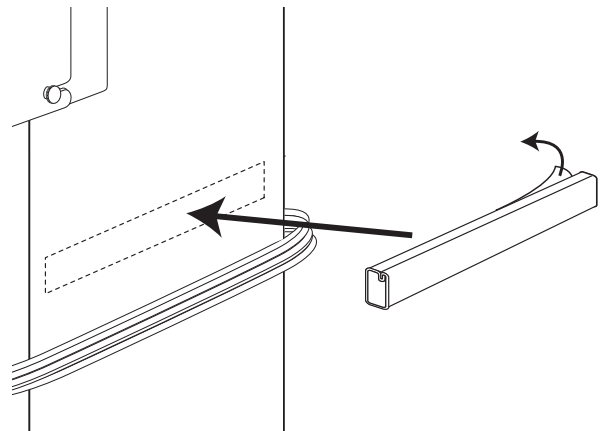

NOTE: ENSURE THE CASING DOES NOT COVER ANY SEAMS OR VENTS ON THE FREEZER.

- 3** Pry open the 9-Tube Assembly Casing and place the cable(s) and/or tubes inside the Casing.

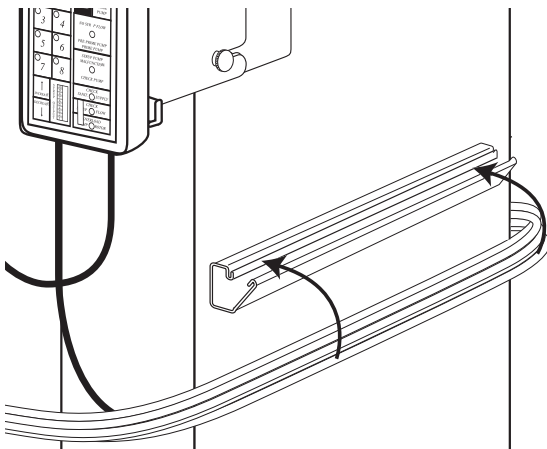

- 4** Close the Casing, and press all along the connection to secure.

