

Flavor Burst™

ELE 510 Switch Kit Various Assembly Configurations

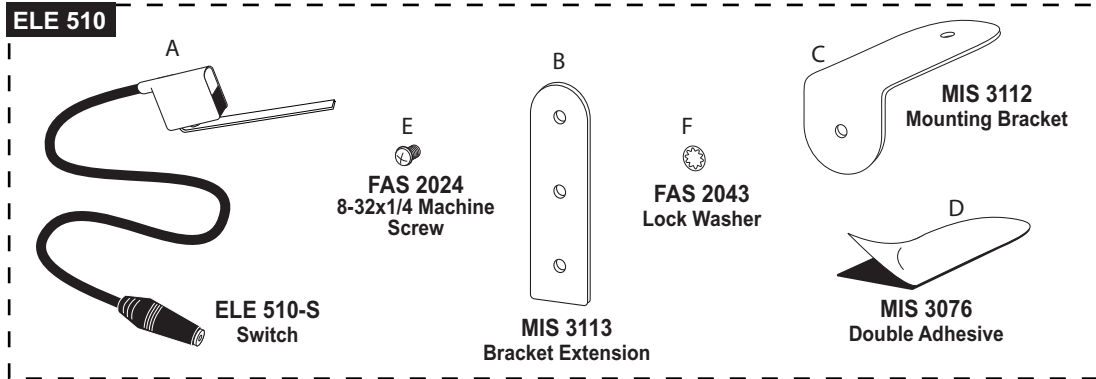

Several mounting solutions are possible using some or all of the switch mounting accessories as shown below.

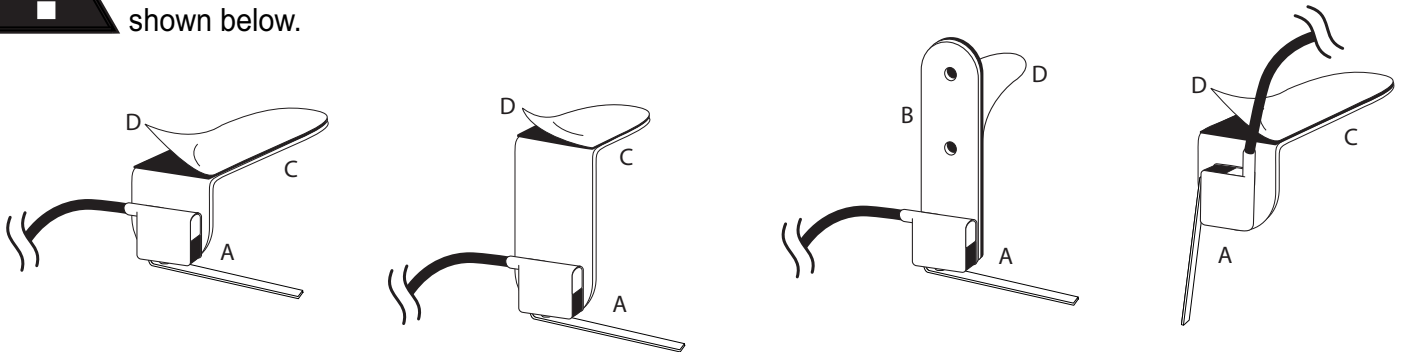

NOTE: WHEN USING BOTH BRACKETS, BE SURE TO INSTALL THE LOCK WASHER (F) BETWEEN THE MOUNTING BRACKET AND BRACKET EXTENSION.

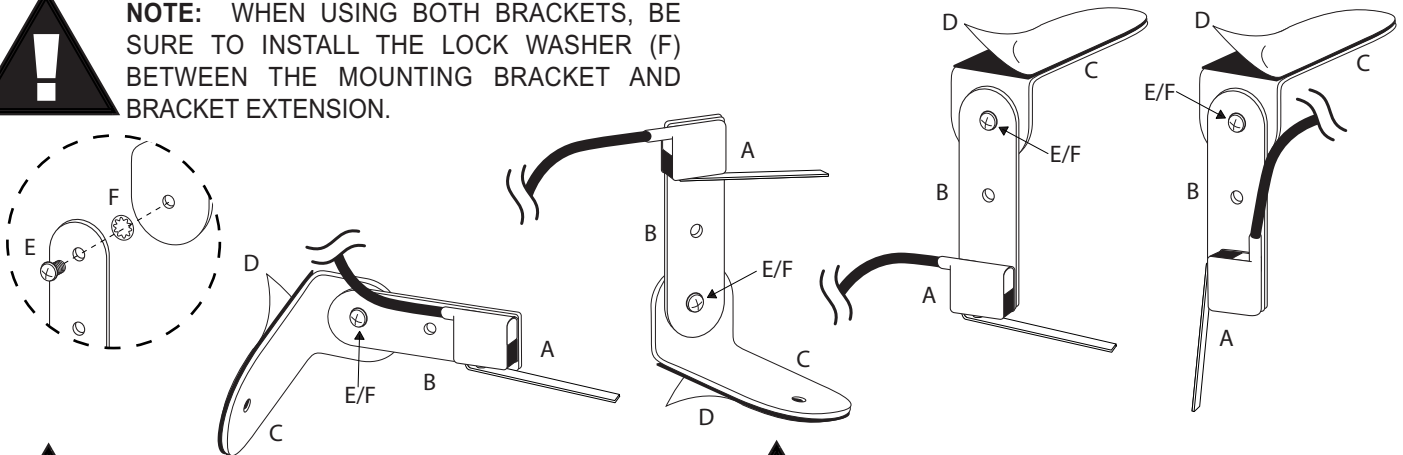

NOTE: WHEN POSSIBLE, THE ELE 510 SWITCH CAN BE MOUNTED DIRECTLY ONTO THE FACE OF THE FREEZER.



NOTE: THE SWITCH LEVER CAN BE CONFIGURED SO IT EXTENDS DOWN TOWARD THE DRAW ROD ON THE FREEZER.

