

Flavor Burst™

CW 176 Mounting Bracket Kit

Installation

This mounting procedure and bracket kit should be used only on freezer models where the freezer operational controls are not obstructed by the mounting base and bracket kit. This secure mounting kit and method is for long-term or permanent mounting of the CC8. Should you require a different mounting kit for your freezer, contact your local distributor for additional information.

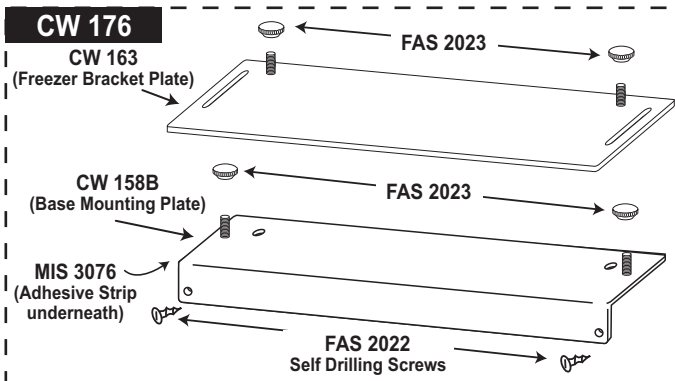

- 2** Assemble the mounting base to the base mounting plate and tighten the thumb nuts to secure. Place the screw studs of the the freezer bracket plate within the base mounting plate grooves as shown. Attach the thumb nuts but do not tighten.

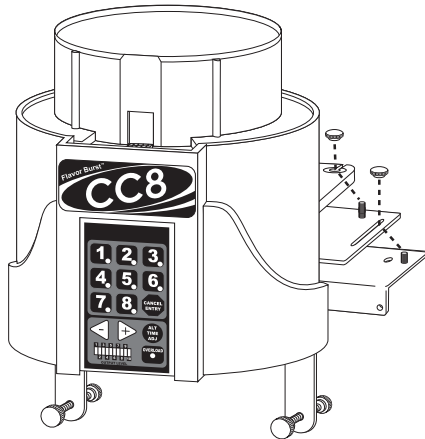

- 4** Set the assembly as far back on the ledge without obstructing any of the freezer operational controls. Slide the base and extension as far back onto the mounting bracket plate as possible and tighten the thumb nuts.

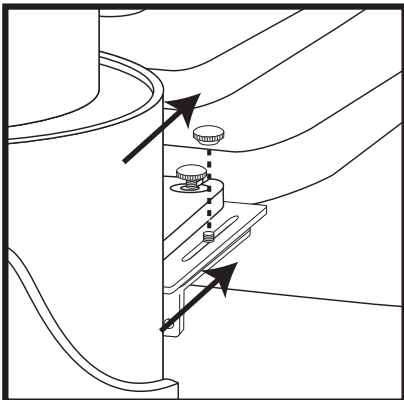

- 1** Thoroughly clean and dry the surfaces of the freezer where the mounting assembly will be attached. Using a soft lead pencil, mark the center of the freezer top, directly above the door spout.

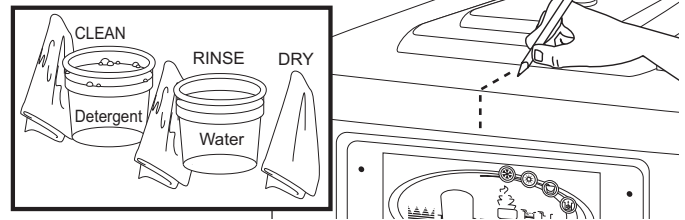

- 3** Position the center of the mounting base assembly within 3 inches left or right of the freezer center. If the draw handle is operated by the left hand, the Mounting Base should be mounted within 3" to the right of the center of the draw handle. Conversely, if the draw handle is operated by the right hand, the Mounting Base should be mounted within 3" to the left of the center of the draw handle.

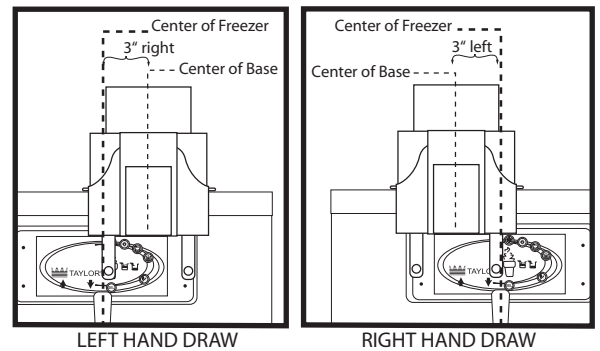

- 5** Use the vertical stabilizer bar screws to extend the bars downward as far as possible without obstructing any freezer operational controls. Tighten the screws to secure the position.

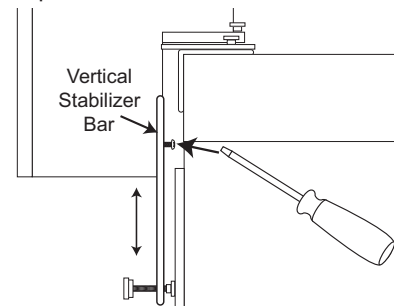

NOTE: REMOVE THE MOUNTING BASE FROM THE BRACKET TO LOOSEN AND TIGHTEN THE VERTICAL STABILIZER BAR SCREWS.

- 6** Using a soft lead pencil, mark around the mounting bracket plate and inside the screw holes of the plate.

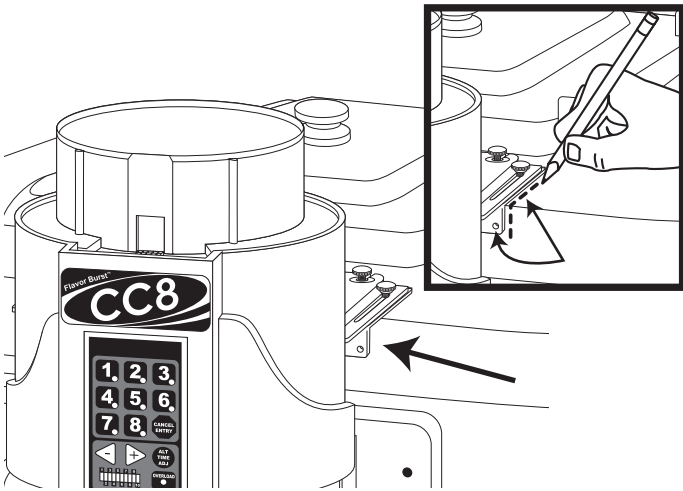

- 7** Remove the mounting bracket plate from the assembly, remove the protective tape from the adhesive, and press the bracket within the pencilled marks on the freezer. Carefully drill a 1/8" hole into the freezer through each of the screw holes.

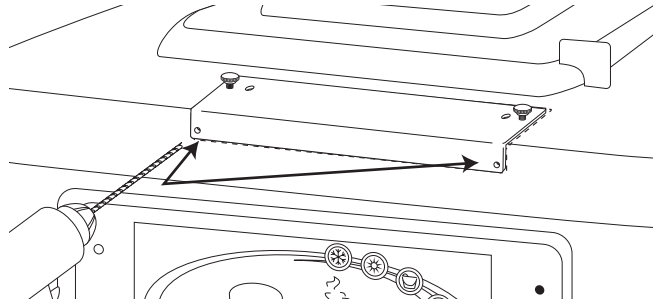

NOTE: BEFORE DRILLING, ENSURE THERE ARE NO WIRES BEHIND THE PANEL WHERE THE DRILL HOLES WILL BE MADE.

- 8** Install the screws into the drilled holes to secure the plate.

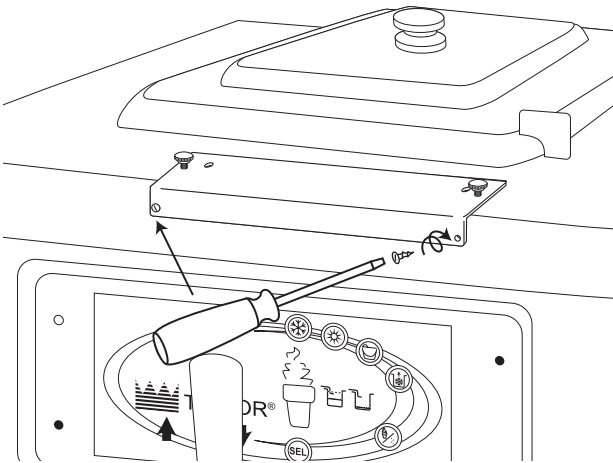

- 9** Remove the thumb nuts from the mounting plate. Install the mounting base onto the freezer bracket plate, slide the base as far back as allows and tighten the thumb nuts of the bracket plate to secure.

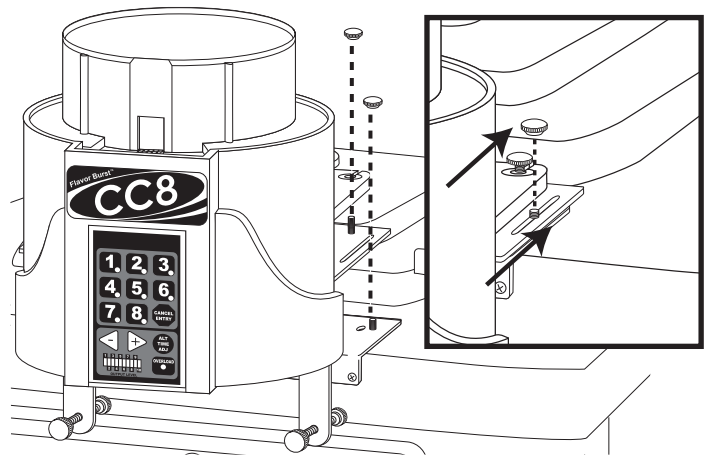

- 10** Adjust the vertical stabilizer bar thumb nuts to ensure the mounting base is level.

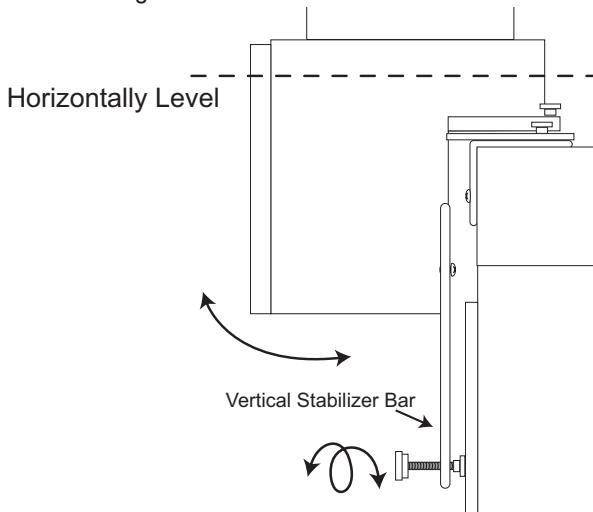

- 11** Ensure the chip hopper funnel is in place within the mounting base and install the carousel over the funnel with the #1 dispensing module in front. Ease the carousel down onto the mounting base until the electrical connection engages.

