

Flavor Burst™

ADPT TYLG-2K1 Taylor® Large Spout Adapter Kit

Assembly and Installation

The ADPT TYLG-2K1 is designed for use with large-spout Taylor® freezer models. If you have any special considerations, please contact your local Flavor Burst™ distributor for additional information.

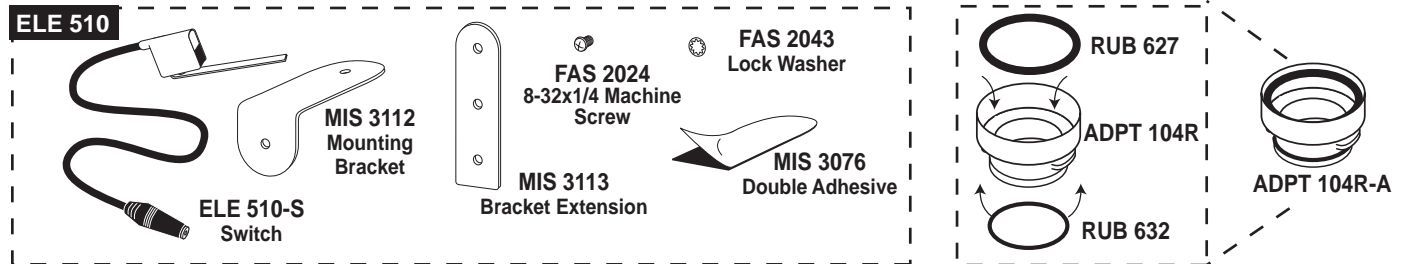

1 Install the two black o-rings onto the ADPT 104R as shown, and then install the ADPT 104R-A adapter onto the freezer spout.

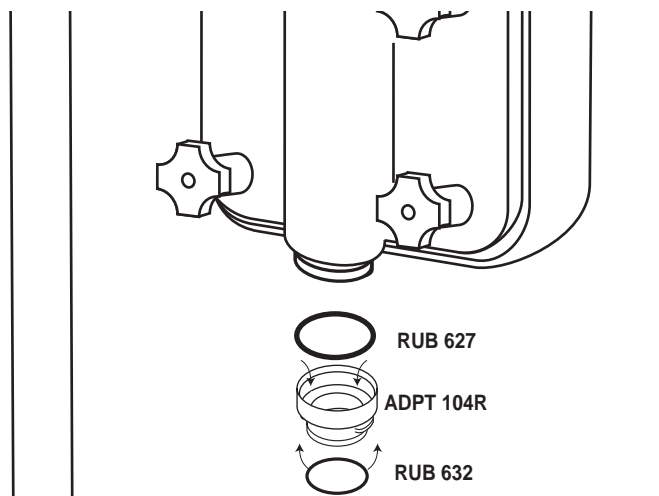

2 Refer to the ELE 510 Information Sheet to determine the best ELE 510 configuration for your freezer, and assemble the switch kit accordingly. For the example shown, attach the ELE 510-S to the Bracket Extension using a portion of the double adhesive, and then use the remaining adhesive to attach the assembly to the freezer.

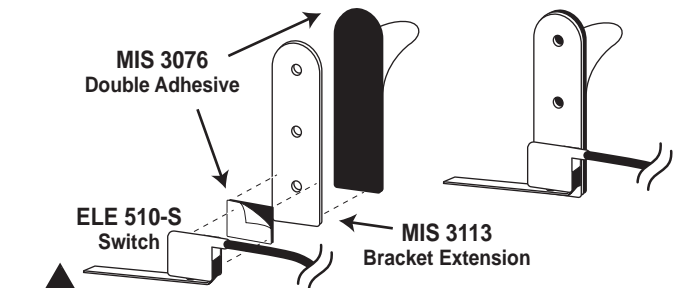

! **NOTE:** MULTIPLE MOUNTING SOLUTIONS ARE POSSIBLE USING SOME OR ALL OF THE SWITCH MOUNTING ACCESSORIES LIKE THE EXAMPLE ABOVE. SEE THE ELE 510 INFORMATION SHEET.

3 Remove the adhesive protective backing and then attach the switch assembly to the freezer so that the end of the switch lever is approximately 1/8" above the draw handle rod.

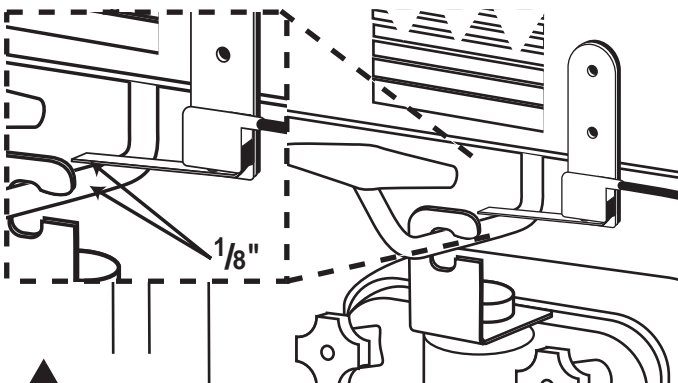

! **NOTE:** THE SWITCH LEVER CAN BE CONFIGURED SO THAT IT EXTENDS DOWN TOWARD THE DRAW HANDLE ROD. SEE THE ELE 510 INFORMATION SHEET.

! **NOTE:** BE SURE TO FULLY ENGAGE THE SPIGOT SWITCH JACK TO THE FLAVOR BURST™ KEYPAD JACK FOR NORMAL OPERATION. DO NOT NEGLECT TO CHECK THIS CONNECTION DURING DAILY STARTUP.

