

Flavor Burst™

ADPT TM-80 Taylormate® Kit

Assembly and Installation

The ADPT TM-80 is designed for use with most Taylormate® Series Freezers. Be sure to contact your local Flavor Burst™ distributor if you have special needs for adapting to your specific Taylormate® model.

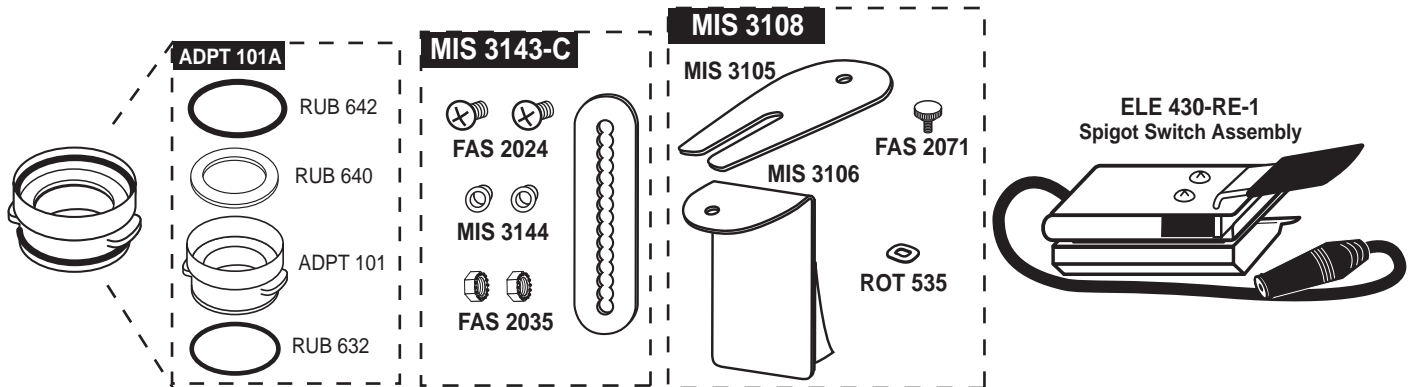

- 1** Assemble and install the Injector Adapter onto the freezer door spout. Ensure the o-rings and gasket are in their proper places.

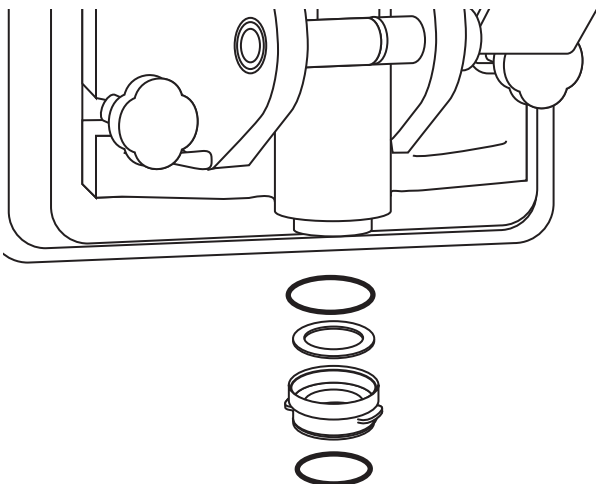

- 2** Slide the Spigot Switch Assembly onto the draw handle.

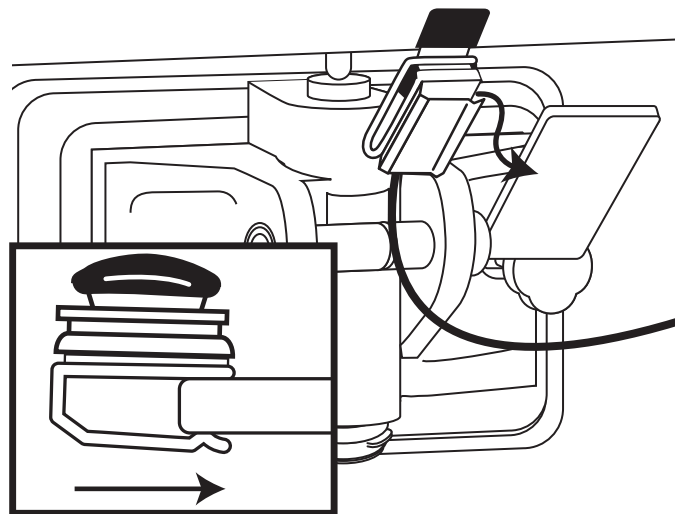

- 3** Slide the Switch Assembly toward the end of the draw handle so that the Switch lever is depressed when the draw handle is grasped.

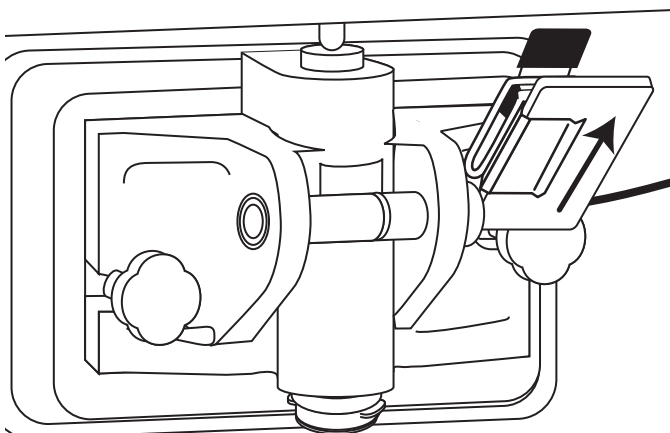

- 4** Be sure to fully engage the Spigot Switch jack to the Flavor Burst™ keypad jack for normal operation. Do not neglect to check this connection during daily startup.

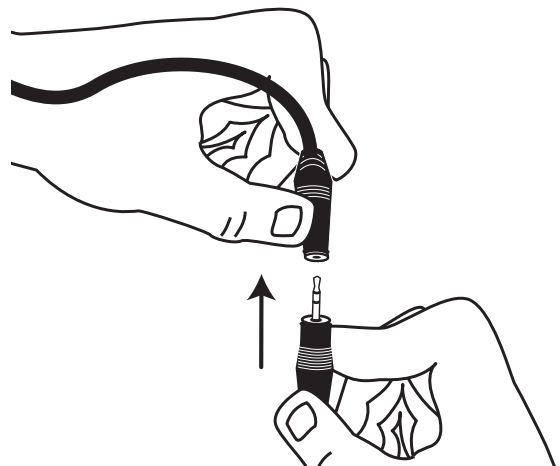

A MIS 3143C SUSPENSION BRACKET EXTENSION

This kit comes with two options for an Injector Mounting Bracket due to freezer model variations. When possible, use the suspension bracket included with your unit and the extensions provided. If the suspension bracket is not suitable for your freezer, install the MIS 3108 mounting bracket in section B.

- 5** If your Injector Assembly has a Suspension Bracket, reassemble the bracket using the extension bracket and fasteners as shown.

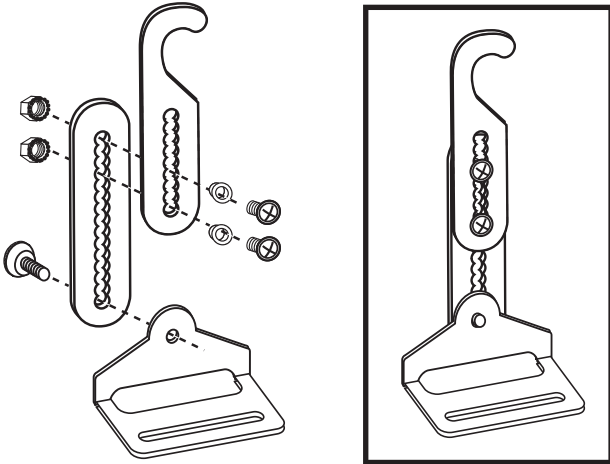

- 6** Attach the Injector Assembly to the spout adapter so that the Injector locking ring covers the adapter tabs. Turn the locking ring 1/4 of a turn to secure.

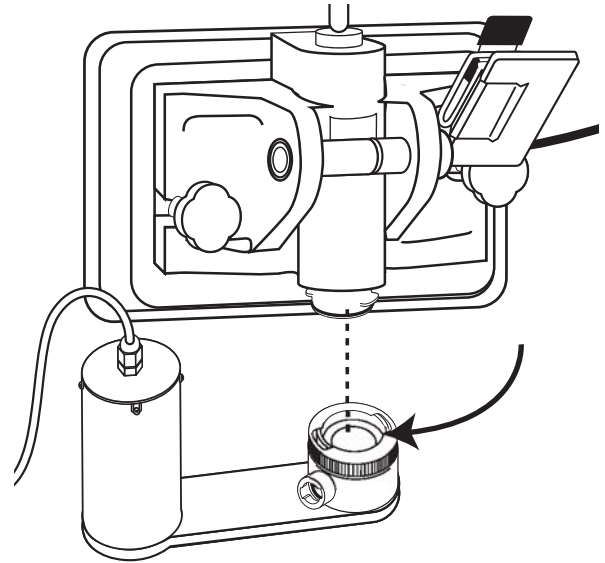

- 7** Hang the Suspension Bracket Assembly on the hand knob of the freezer nearest the Injector Assembly. Position the Bracket so that the bottom plate is underneath the Injector Assembly and the threaded post slides through the bracket plate slot.

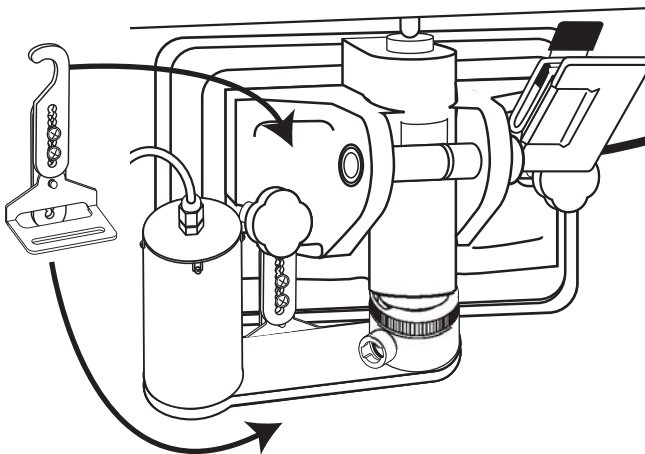

- 8** Using the adjustment screws, lengthen or shorten the bracket so that it supports the Injector Assembly in a level position. Also, install the Gear Box thumb nut onto the threaded post of the Gear Box. Tighten the screws and knob to complete the installation.

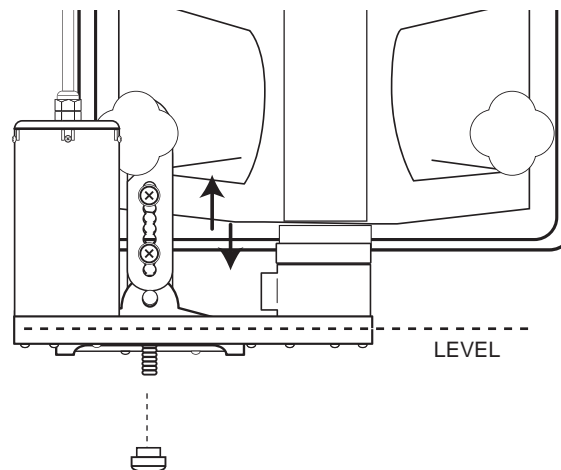

B MIS 3108 MOUNTING BRACKET

- 9** Assemble the Mounting Bracket. Ensure the washer is between the upper plate and the base plate.

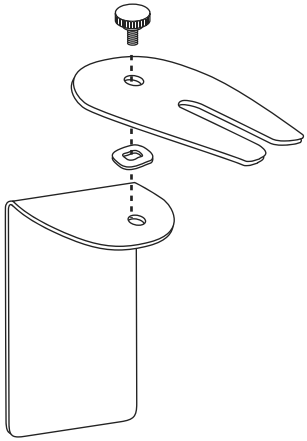

- 10** Attach the assembled MIS 3108 Mounting Bracket to the Injector System and then connect the Injector Head to the Injector Adapter.

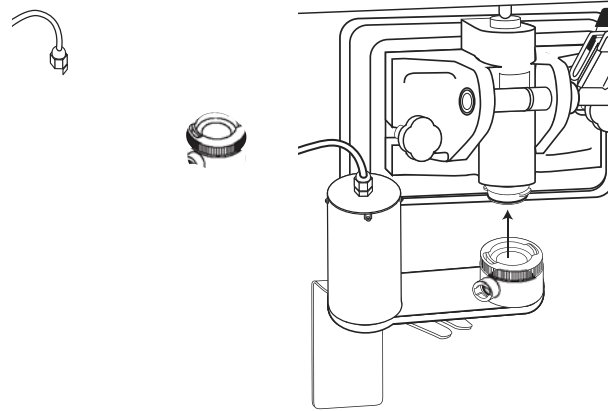

- 11** Position the Injector Assembly and Mounting Bracket so that they are horizontally level.

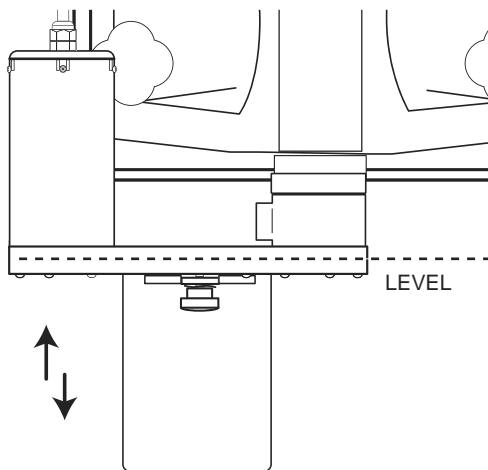

- 12** Move the bracket into position on the face of the freezer and ensure the Injector Assembly is level. On the freezer panel, mark around the bottom and sides of the bracket using a pencil.

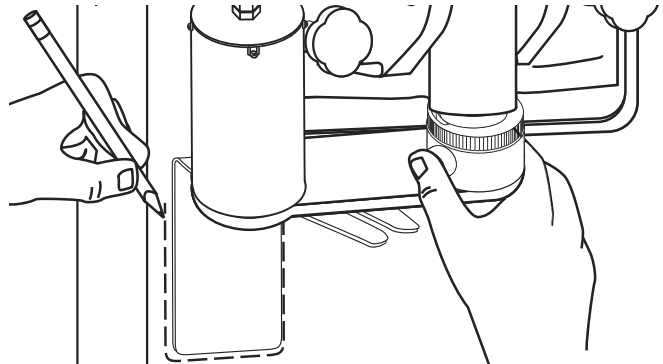

NOTE: BE SURE THE SURFACE OF THE FREEZER WHERE THE BRACKET BASE WILL BE ATTACHED IS THOROUGHLY CLEAN AND DRY.

- 13** Disconnect the Injector Assembly from the Adapter. Remove the protective backing from the adhesive strip on the bracket base. Press firmly against the freezer.

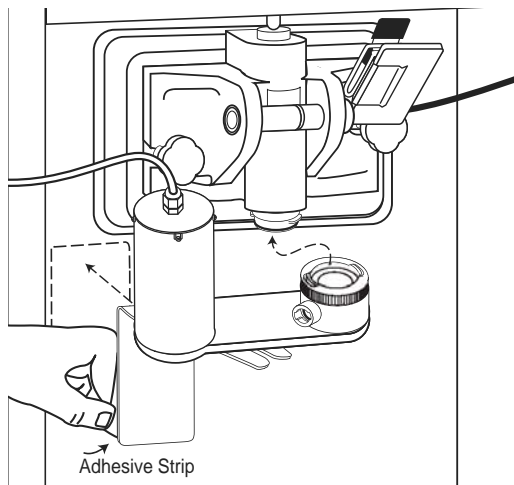

- 14** Reattach the Injector Head to the Adapter to complete the assembly and installation of the Mounting Bracket.

