

# Flavor Burst™

## ADPT EF-80 Electrofreeze® Adapter Kit

### Assembly and Installation

This Adapter Kit is designed for use with most Electrofreeze® models. If you have a large Electrofreeze® door spout or other special considerations, contact your local Flavor Burst™ distributor for additional information.

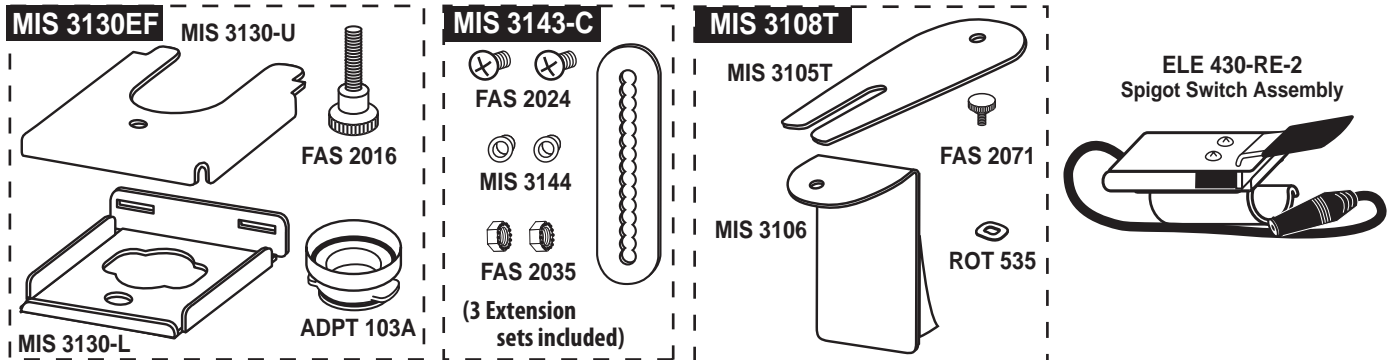

**1** Rotate the Switch Assembly onto the draw-handle bar.

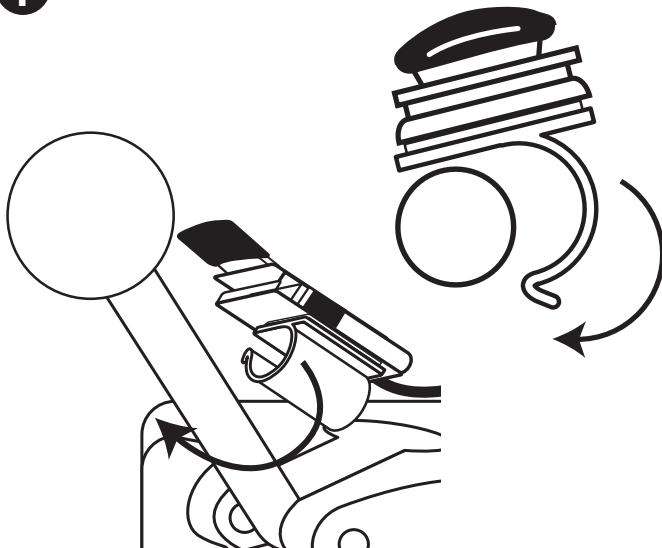

**2** Position the Switch up towards the end of the draw-handle bar to complete the Installation.

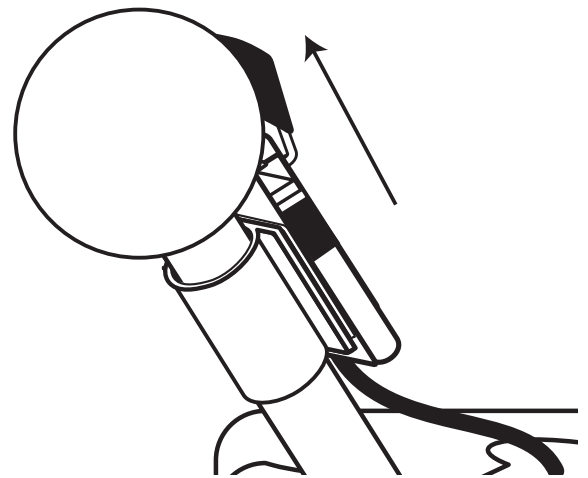

**3** Be sure to fully engage the Spigot Switch jack to the Flavor Burst™ keypad jack for normal operation.

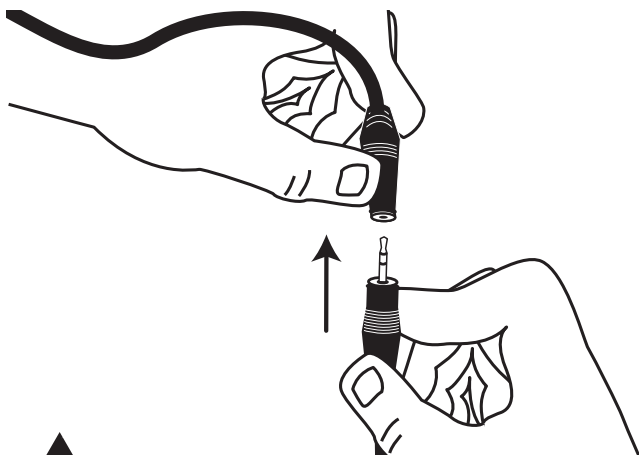

**4** Install the black o-rings on the Adapter, set it inside the Bracket Base, and then attach it to the freezer door spout.

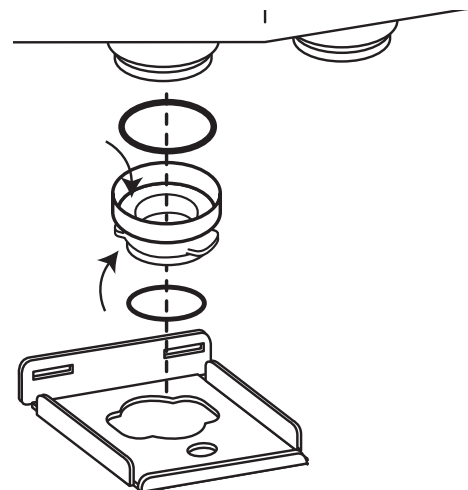

**NOTE:** DO NOT NEGLECT TO CHECK THIS CONNECTION DURING DAILY STARTUP.

- 5** Slide the Bracket Cover over the Adapter & Bracket Base. Be sure that the tabs of MIS 3130-U slide into the slots of MIS 3130-L.

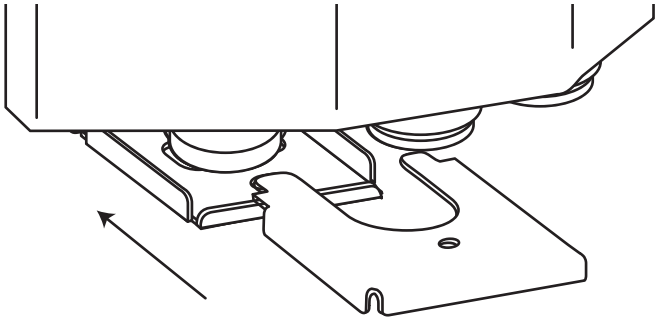

- 6** Thread the Hand Screw through the two bracket parts until snug to secure.

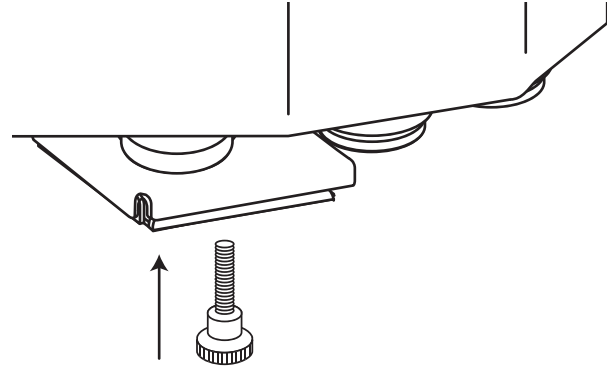

## A MIS 3143C SUSPENSION BRACKET EXTENSION

This kit comes with two options for an Injector Mounting Bracket due to freezer model variations. When possible, use the suspension bracket included with your unit and the extensions provided. If the suspension bracket is not suitable for your freezer, install the MIS 3108T mounting bracket in section B.

- 7** If your Injector Assembly has a Suspension Bracket, reassemble the bracket using the extension bracket and fasteners as shown.

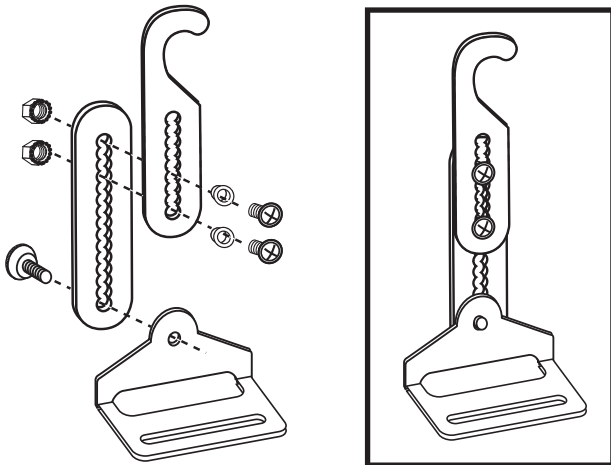

**NOTE:** IF MORE HEIGHT IS NEEDED, USE MULTIPLE EXTENSION BRACKET KITS WITH THE SUSPENSION BRACKET.

- 8** Hang the Suspension Bracket Assembly on the hand knob of the freezer nearest the Injector Assembly. Position the Bracket so that the bottom plate is underneath the Injector Assembly and the threaded post slides through the bracket plate slot.

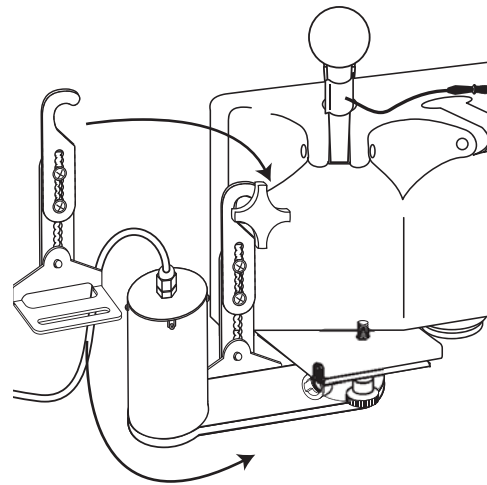

- 9** Using the adjustment screws, lengthen or shorten the bracket so that it supports the Injector Assembly in a level position. Tighten to secure.

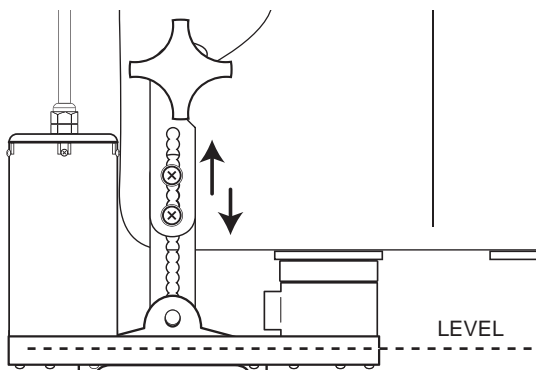

- 10** Install the Gear Box thumb nut onto the threaded post of the Gear Box and tighten to complete the installation.

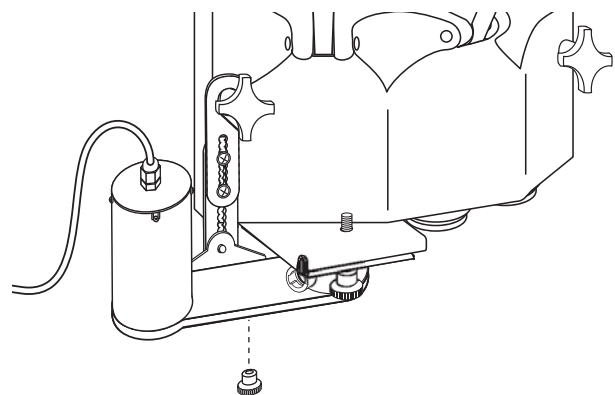

## B MIS 3108T MOUNTING BRACKET

- 11** Assemble the Mounting Bracket. Ensure the washer is between the upper plate and the base plate.

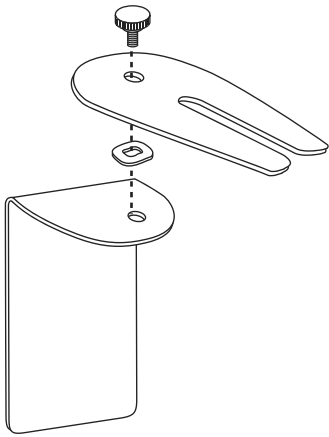

- 12** Attach the assembled MIS 3108T Mounting Bracket to the Injector System and then connect the Injector Head to the Injector Adapter.

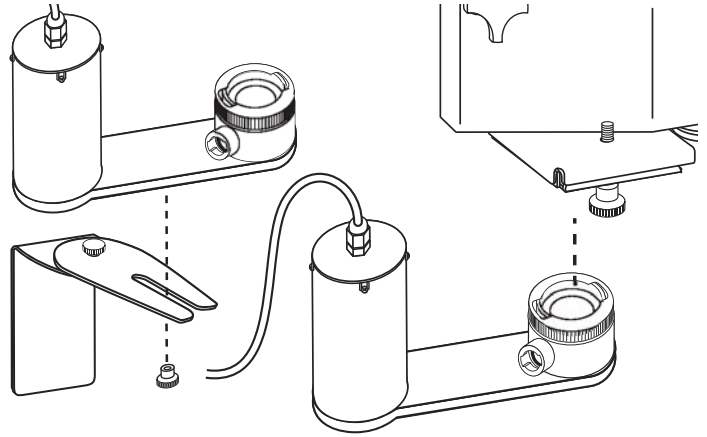

- 13** Position the Injector Assembly and Mounting Bracket so that they are horizontally level.

- 14** Move the bracket into position on the face of the freezer and ensure the Injector Assembly is level. On the freezer panel, mark around the bottom and sides of the bracket using a pencil.

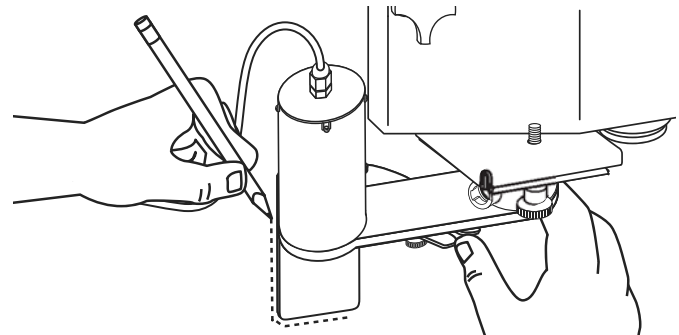

**NOTE:** BE SURE THE SURFACE OF THE FREEZER WHERE THE BRACKET BASE WILL BE ATTACHED IS THOROUGHLY CLEAN AND DRY.

**15**

**16**

