

Flavor Burst™

ADPT CLD2-80 Coldelite® Adapter Kit

Installation

This adapter kit is designed for Coldelite® freezer models with larger freezer doors (i.e. UF 820E). If you have other special considerations, please contact your local Flavor Burst® distributor for additional information.

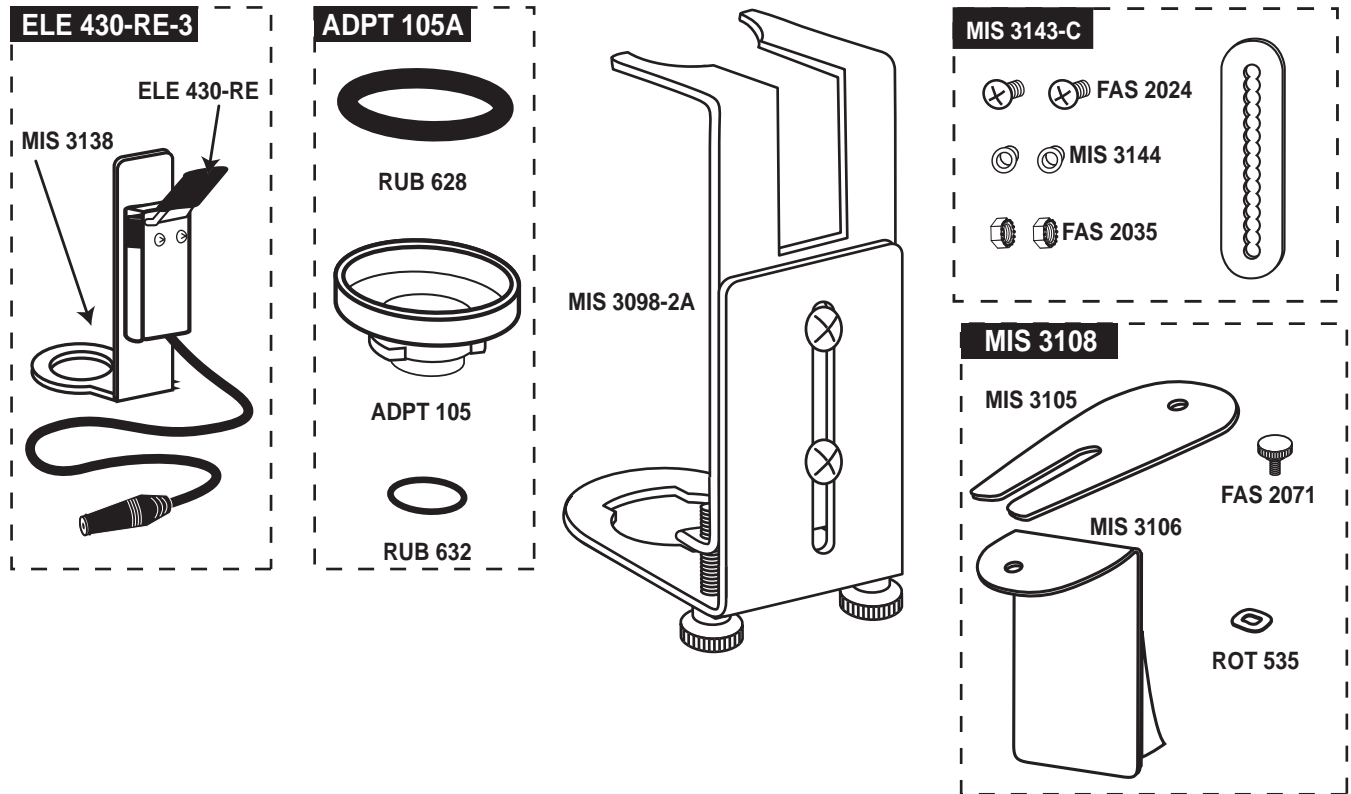

- 1 Ensure that the bracket hand screws are as loose as possible, but still threaded into the upper bracket.
- 2 Lube each o-ring lightly and install them on the Adapter.

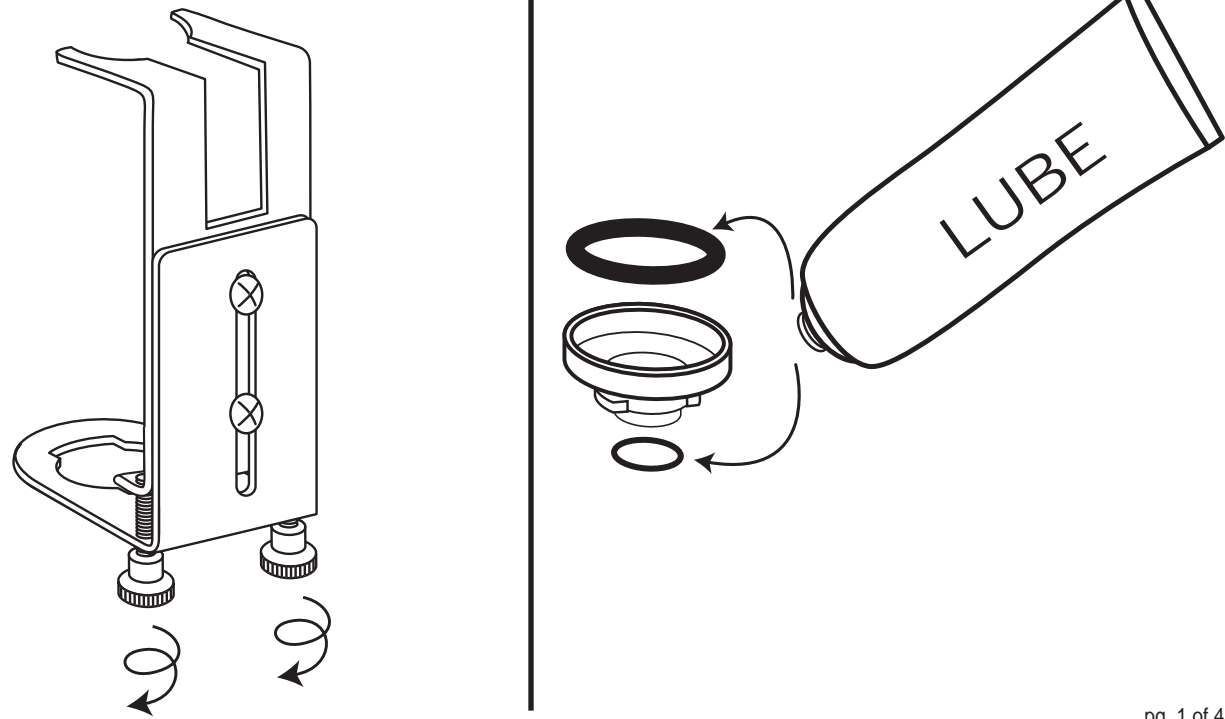

- 3** Set the Adapter into the lower bracket base and turn off-center to secure.

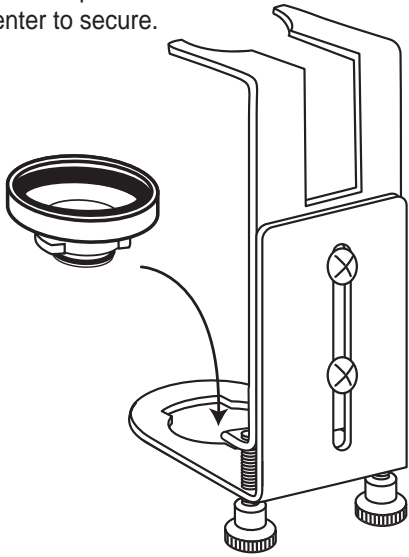

- 4** Slide the Bracket Assembly over the freezer handle and door spout so that the Adapter is positioned directly below the spout opening.

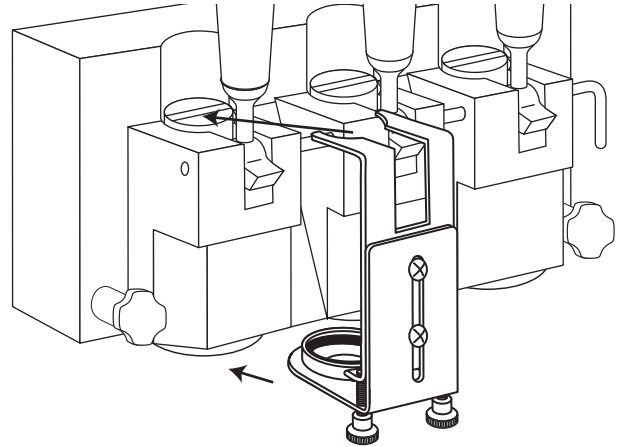

- 5** Tighten each hand screw firmly, then tighten each bracket screw to secure the assembly.

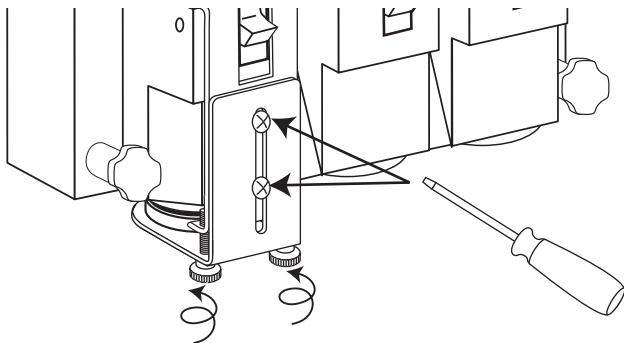

! **NOTE:** BOTH BRACKET SCREWS SHOULD TIGHTEN FULLY AGAINST THE BRACKET ASSEMBLY, ALTHOUGH THE CORRESPONDING NUT WILL REMAIN LOOSE IN MOST INSTALLATIONS.

- 6** Remove the freezer handle and install the Switch Assembly over the exposed threads.

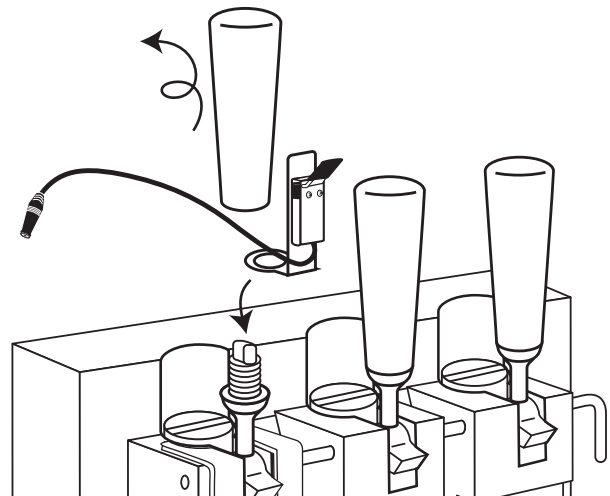

- 7** Replace the freezer handle and ensure that the Switch Assembly is the desired position as you secure the handle.

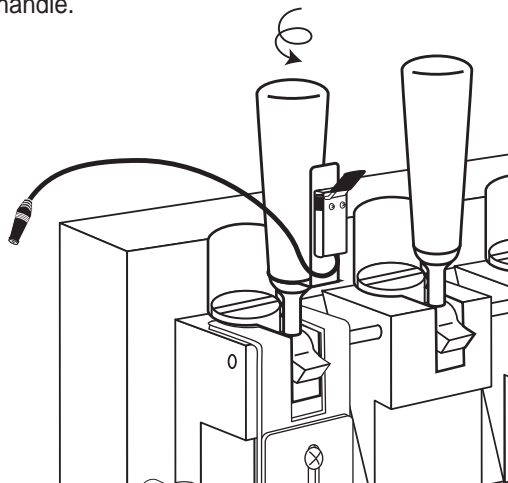

- 8** Be sure to fully engage the Spigot Switch jack to the keypad jack for normal operation.

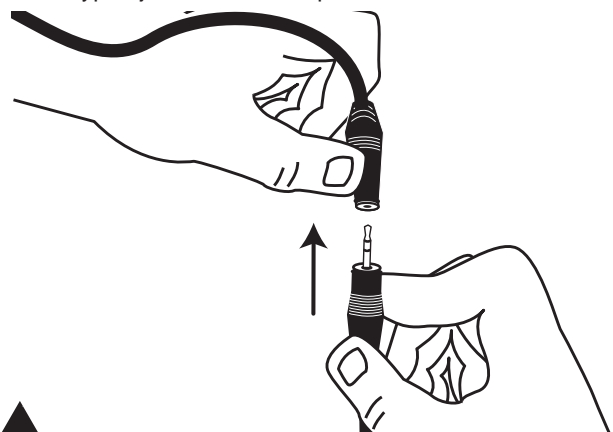

! **NOTE:** DO NOT NEGLECT TO CHECK THIS CONNECTION DURING DAILY STARTUP.

A MIS 3143C SUSPENSION BRACKET EXTENSION

This kit comes with two options for an Injector Mounting Bracket due to freezer model variations. When possible, use the suspension bracket included with your unit and the extensions provided. If the suspension bracket is not suitable for your freezer, install the MIS 3108 mounting bracket in section B.

9 If your Injector Assembly has a Suspension Bracket, reassemble the bracket using the extension bracket and fasteners as shown.

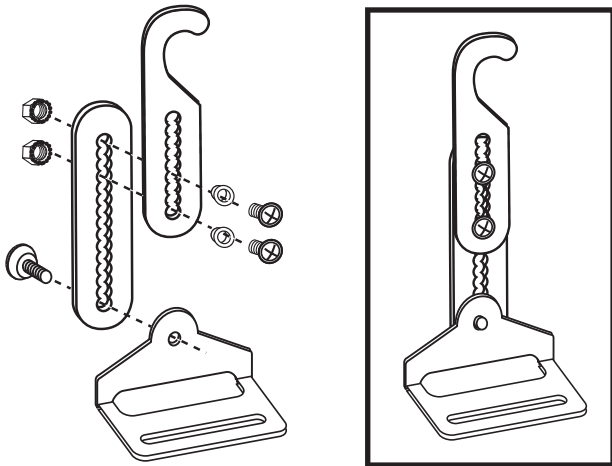

10 Attach the Injector Assembly to the spout adapter so that the Injector locking ring covers the adapter tabs. Turn the locking ring 1/4 of a turn to secure.

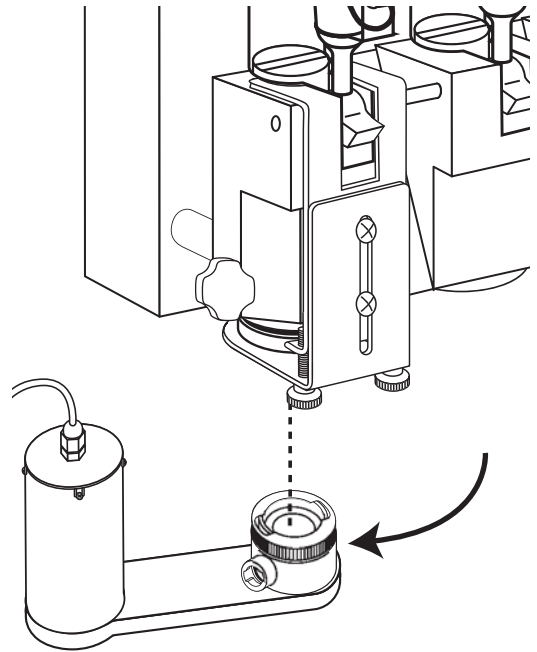

11 Hang the Suspension Bracket Assembly on the hand knob of the freezer nearest the Injector Assembly. Position the Bracket so that the bottom plate is underneath the Injector Assembly and the threaded post slides through the bracket plate slot.

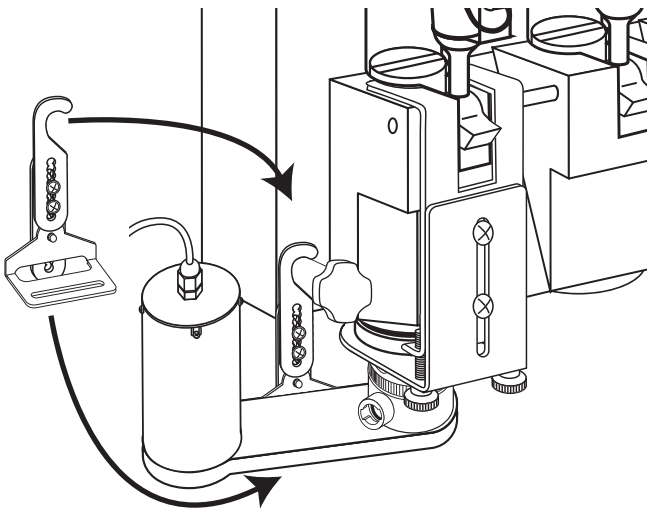

12 Using the adjustment screws, lengthen or shorten the bracket so that it supports the Injector Assembly in a level position. Also, install the Gear Box thumb nut onto the threaded post of the Gear Box. Tighten the screws and knob to complete the installation.

