

# Flavor Burst™

## ADPT SS-2 2K1 SaniServ® Series 500 Adapter Kit Assembly and Installation

The ADPT SS-2 2K1 kit is designed for use with SaniServ® Series 500 freezers to secure the Flavor Burst™ Injector System to the door spout. If you require any special considerations, please contact your local Flavor Burst™ distributor for additional information.

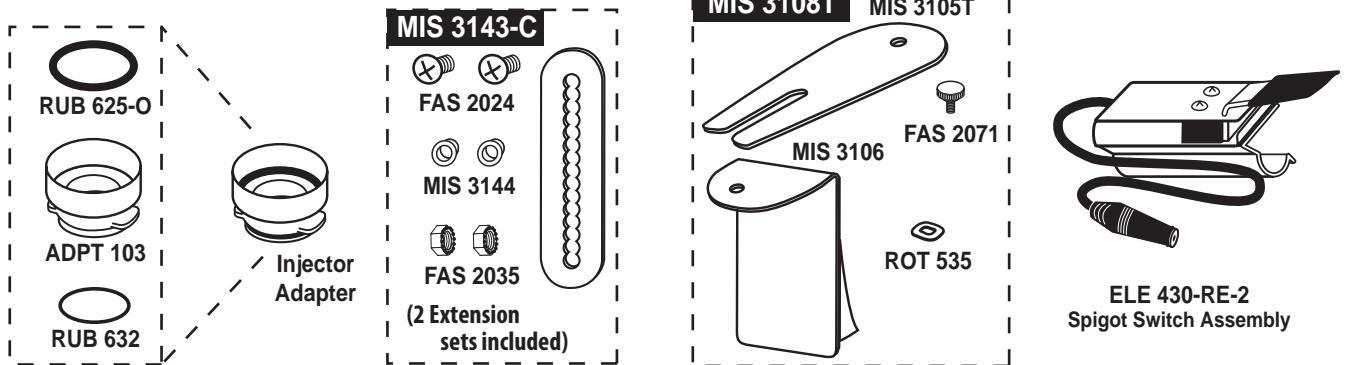

**1** Rotate the Switch Assembly onto the draw-handle bar.

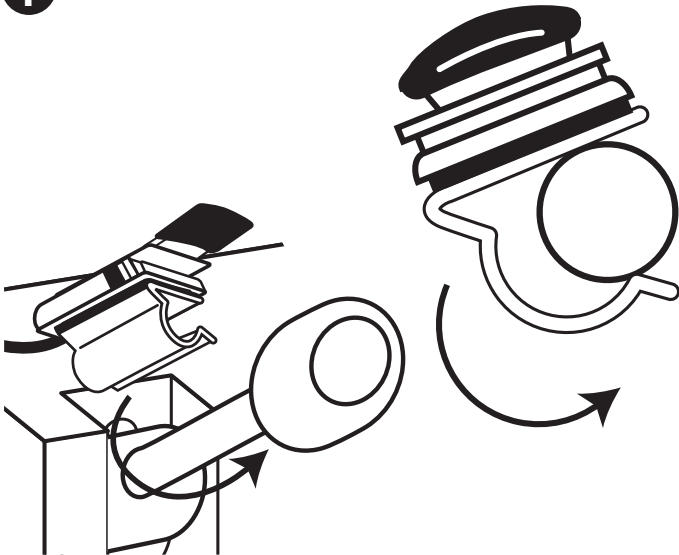

**2** Position the Switch up towards the end of the draw-handle bar to complete the Switch installation.

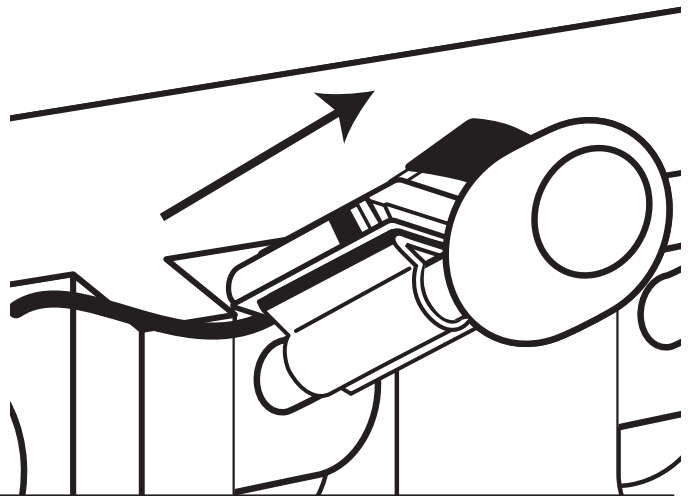

**3** Be sure to fully engage the Spigot Switch jack to the Flavor Burst™ keypad jack for normal operation.

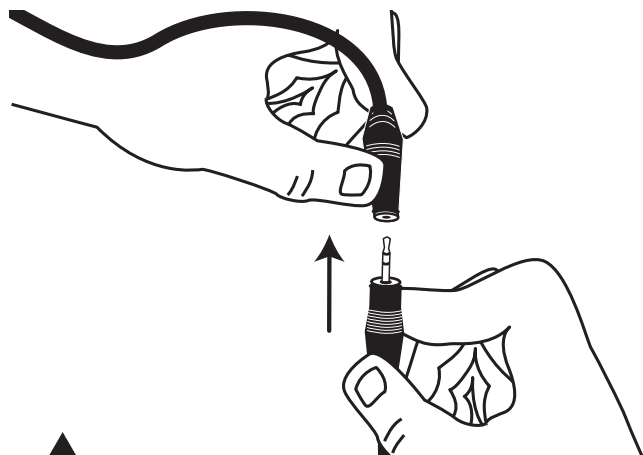

**4** Install the black o-rings on the Adapter and then attach it to the freezer door spout.

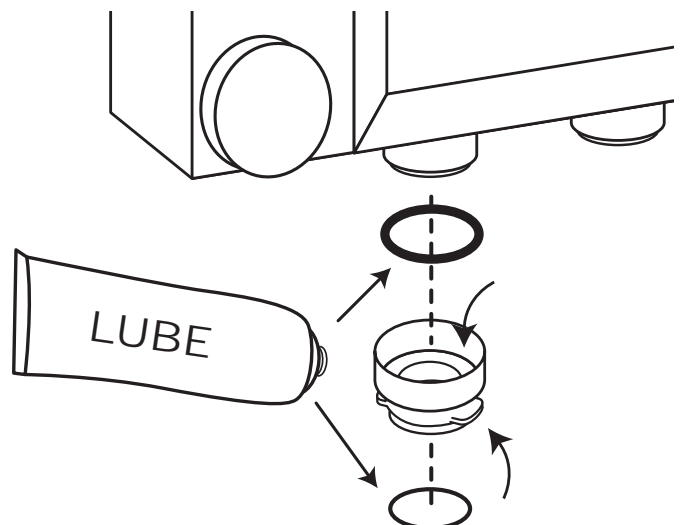

**!** **NOTE:** DO NOT NEGLECT TO CHECK THIS CONNECTION DURING DAILY STARTUP.

# A MIS 3143C SUSPENSION BRACKET EXTENSION

This kit comes with two options for an Injector Mounting Bracket due to freezer model variations. When possible, use the suspension bracket included with your unit and the extensions provided. If the suspension bracket is not suitable for your freezer, install the MIS 3108T mounting bracket in section B.

**5** If your Injector Assembly has a Suspension Bracket, reassemble the bracket using the extension bracket and fasteners as shown.

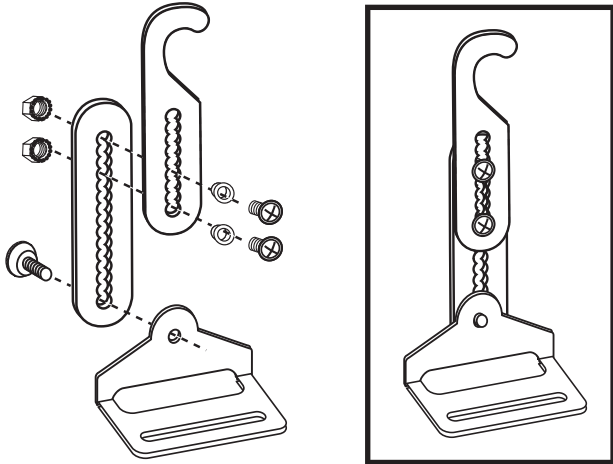

**NOTE:** IF MORE HEIGHT IS NEEDED, USE BOTH OF THE EXTENSION BRACKET KITS WITH THE SUSPENSION BRACKET.

**6** Attach the Injector Assembly to the spout adapter so that the Injector locking ring covers the adapter tabs. Turn the locking ring 1/4 of a turn to secure.

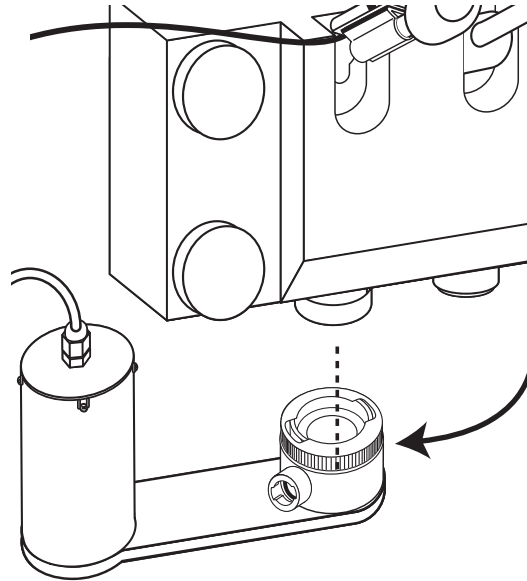

**7** Hang the Suspension Bracket Assembly on the hand knob of the freezer nearest the Injector Assembly. Position the Bracket so that the bottom plate is underneath the Injector Assembly and the threaded post slides through the bracket plate slot.

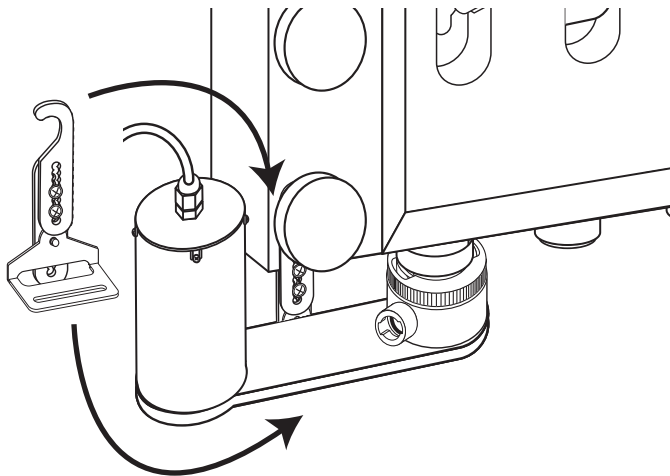

**8** Using the adjustment screws, lengthen or shorten the bracket so that it supports the Injector Assembly in a level position. Also, install the Gear Box thumb nut onto the threaded post of the Gear Box. Tighten the screws and knob to complete the installation.

